

Mini Loader by Dingo Australia

SM275-19W



**WACKER
NEUSON**

all it takes!



Wacker Neuson SM275-19W - Design & Innovation meets Powerful Performance

Designed and manufactured exclusively for Wacker Neuson by Dingo Australia, powered by the diesel engine, the SM275-19W is the ideal platform for worksites, owner-operators and DIY'ers. The lean fuel burn of the Kohler, delivers excellent fuel economy reducing running costs.

Pressure and flow to the wheels and your attachments are the heart of any mini loader - it's how you earn your living. You want the very best - and that's what a SM275-19W provides consistently - day after day, year after year!

Combining the unique hydraulic design of the Wacker Neuson mini-loader with the Kohler engine, provides the perfect partnership of power, pressure and durability for every application.

The SM275-19W has the most robust chassis on the market - this moves the weight down to the wheels where you need it.

The lower centre of gravity gives you best in class traction and trenching with up to 30% more pull and 30% more push power.

The Wacker Neuson Dingo all-wheel drive SM275-19W is perfect for all terrains.

With the optional narrow wheel and hub set you can quickly change your set up to narrow access whenever you need – as narrow as 780mm – eliminating the need for a second machine.

Achieve more with the best and highest lift for the weight class. Our proven bushing system has no steel on steel wear - which means no grease, no mess resulting in less maintenance and longer machine life!

Protected by our tough powder-coated finish, your SM275-19W will stand up against the harshest of conditions.

Wacker Neuson SM275-19W made by Dingo Australia, working as hard as you do!

Dimensions

Overall width	850 - 1050 mm
Overall length	1,600 mm
Overall height	1,200 mm
Max operating height 4 in 1	2,080 mm
Turning radius with 4 in 1 bucket	1,300 mm
Angle of departure	25°
Wheel base	800 mm
Ground clearance	135 mm
Dump height standard bucket	1,450 mm
Dump height 4 in 1 bucket	1,835 mm
Reach fully raised 4 in 1 bucket	800 mm
Height to hinge pin	1,940 mm
Machine width 4 in 1 bucket	1,050
Hydraulic reservoir capacity	76 L
Machine mass	847 kg
Warranty	5 years / 5,000hrs

Performance

Engine	Diesel KD425
Engine make	Kohler
Engine horsepower	20 hp
Hydraulic horsepower	19.2 hhp
Hydraulic pumps	2 pumps
Pump sizes	9 & 3.5cc
Relief pressure (AUX)	3,000 psi (206 bar)
Hydraulic output	38 L/m
Max travel speed	5 km / h
Rated lift capacity	275 kg WLL

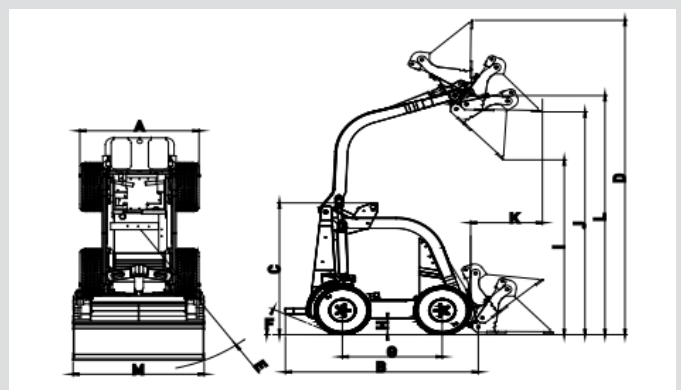

Mini Loader by Dingo Australia

SM275-19W

**ASK ABOUT
THE BEST
HEAVY INDUSTRY
WARRANTY
5 YEARS**

**WACKER
NEUSON**
all it takes!

Wacker Neuson 5 years / 5,000 warranty.

2 pump hydraulic system
equals cooler oil - powers both your Dingo and attachments at the same time without robbing power from either.

Flow Divider -
infinite proportional control of flow without restriction

Grease free maintenance cleaner machine and work environment.

Quick hitch system - for fast and simple change between attachments

Soft touch controls
Minimise fatigue while providing accurate control

1,835mm lift – lifts into utes & most trucks, tips over fences.

High Flow Auxiliary Hydraulic for powering attachments through the toughest conditions and quick couplers for easy connection to the whole family of attachments.

Large hydraulic oil reservoir.

More oil = cooler oil

Cooler oil = better operation

Better operation = faster jobs, longer machine life.

Tough powder coated finish.

Low centre of gravity increases traction. Improves machine stability. Better operator comfort.

180° access - safer for operators - no risk of being trapped from behind.

Rupture resistant fuel tank full vented cap with true-fill opening for easier refuelling.

All wheel drive system through 4 specifically designed and manufactured drive motors.

