

# Toro® Dingo® Wheeled Models Specifications

## TORO DINGO WHEELED MODELS

**323** Kohler® Command Series 23 hp

**220** Kohler Command Series 20 hp

### ENGINE

Cooling System Models 323/220: Air cooled

Fuel Tank Models 323/220 – 2 tanks, 4 gallon (15 liter) capacity each

Oil Capacity Models 323/220 – 2 quarts (1.9 liter)

Air Filter Model 323 – High capacity dry-type remote air cleaner  
Model 220 – Standard dry-type with pre-cleaner

### HYDRAULIC SYSTEM

Pressure Models 323/220 – 3250 psi system relief pressure

Flow Models 323/220 – 4.0 gpm low-flow hydraulic circuit;  
10.8 gpm high flow hydraulic circuit

Reservoir

Capacity 14.8 gallon (56 liter)

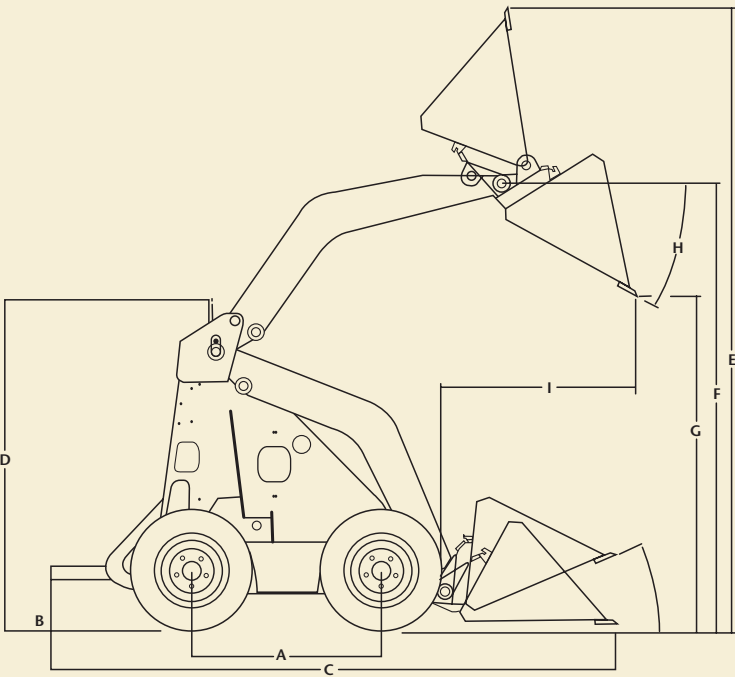

## DIMENSIONS

### 323

### 220

<b>A</b> Wheelbase	28" (71 cm)	28" (71 cm)
<b>B</b> Ground Clearance	5.8" (15 cm) front; 5.8" (15 cm) rear	5.8" (15 cm) front; 5.8" (15 cm) rear
<b>C</b> Overall Length	62" (157.5 cm); 82.2" (208.8 cm) w/bucket	62" (157.5 cm); 82.2" (208.8 cm) w/bucket
Overall Width	40.5" (103 cm) standard tires; 35" (90 cm) narrow tires	40.5" (103 cm) standard tires; 35" (90 cm) narrow tires
<b>D</b> Overall Height	48.7" (123.7 cm)	48.7" (123.7 cm)
<b>E</b> Maximum Operating Height	91.2" (231.6 cm)	91.2" (231.6 cm)
<b>F</b> Hinge Pin Height	66" (167.6 cm) std. bucket – highest position	66" (167.6 cm) std. bucket – highest position
<b>G</b> Dump Height	47" (119 cm) std. bucket	47" (119 cm) std. bucket
<b>H</b> Dump Angle	34° std. bucket	34° std. bucket
<b>I</b> Reach – max.	28" (71.1 cm) std. bucket	28" (71.1 cm) std. bucket
Ground Speed	4.5 mph forward/reverse	4.5 mph forward/reverse
Tip Capacity	1030 lbs. (467 kg)	1030 lbs. (467 kg)
SAE J818 Rating 50% Tip Capacity w/ 200 lbs. (91 kg) operator	515 lbs. (234 kg)	515 lbs. (234 kg)
Weight (w/ std. bucket)	1713 lbs. (777 kg)	1576 lbs. (715 kg)
Weight (w/o bucket)	1567 lbs. (711 kg)	1430 lbs. (649 kg)