

T590 Compact Tracked Loader

Specifications & Options

T590

Machine Rating

Rated operating capacity (ISO 14397-1)	971 kg
Tipping load (ISO 14397-1)	2,774 kg
Pump capacity	64.7 L/min
Pump capacity (with high flow option)	101.1 L/min
System relief at quick couplers	23.8-24.5 MPa
Max. travel speed (high range – optional)	16.7 km/h

Engine

Make / Model	Bobcat / D24
Compliance	97/68 EC Stage IIIB
Fuel	Diesel
Cooling	Liquid
Power	49.2 kW
Torque at 1500 RPM (SAE J1995 Gross)	245 Nm
Number of cylinders	4
Displacement	2,392 cm ³
Fuel tank	138.2 L

Weights

Operating weight	3,548 kg
Shipping weight	3,187 kg

Dimensions

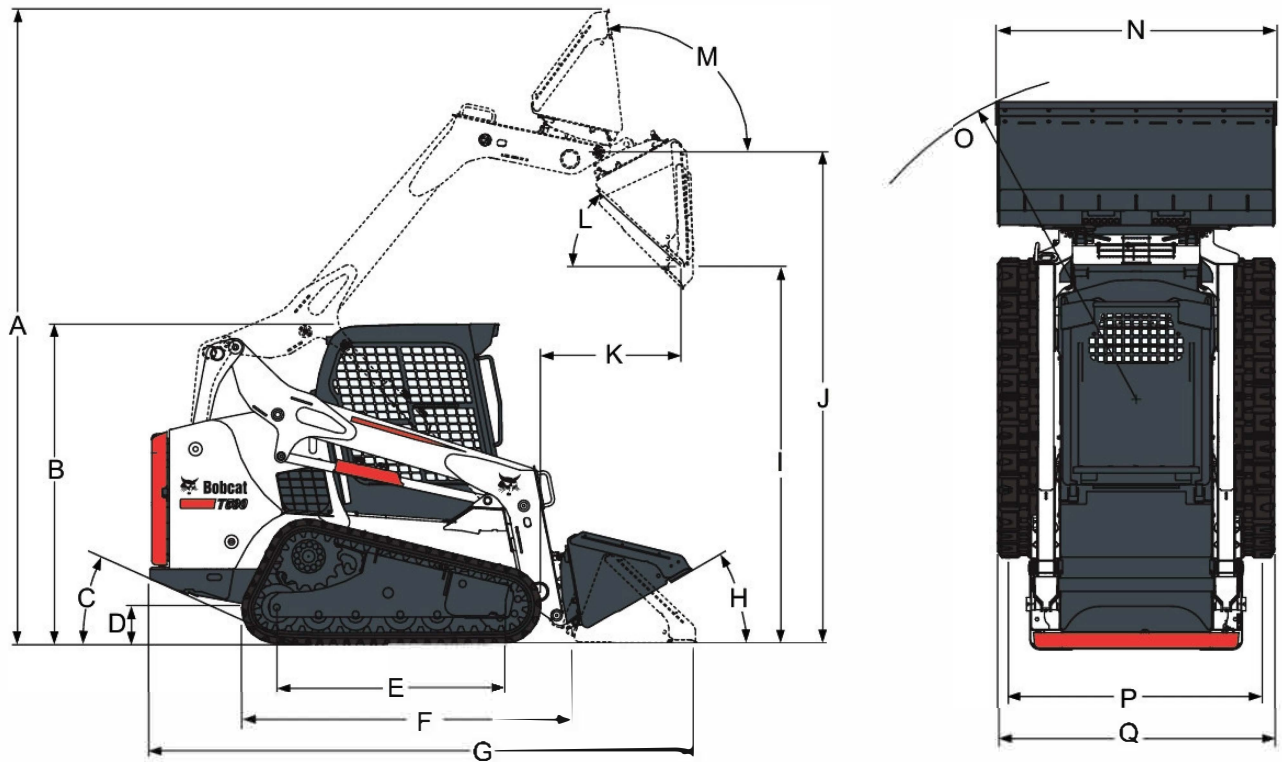

(A)	Operating height	3,901 mm
(B)	Height with operator cab	1,972 mm
(C)	Angle of departure	28.8 °
(D)	Ground clearance	240 mm
(E)	Ground contact length	1,402 mm
(F)	Length without attachment	2,657 mm
(G)	Length with standard bucket	3,378 mm
(H)	Rollback at ground position	30 °
(I)	Dump height with standard bucket	2,319 mm
(J)	Height to bucket hinge pin	3,023 mm
(K)	Dump reach at maximum height	887 mm
(L)	Dump angle at maximum height	42 °
(M)	Rollback fully raised at maximum height	97 °
(N)	Bucket width, 68-inch	1,727 mm
(N*)	Bucket width, 74-inch	1,880 mm
(O)	Turning radius with standard bucket	2,032 mm
(P)	Track, 320 mm tracks	1,384 mm
(Q)	Width over tracks, 320 mm tracks	1,704 mm